

Deformation produces inhomogeneous distribution of dislocations; therefore, an inhomogeneous mean free path and an inhomogeneous κ . This can cause H_n/H_{c2} ratios greater than the ideal value 1.69. However, in an alloy, the mean free path is controlled primarily by solute concentration and variations in dislocation density cause much smaller variations in κ than in pure material. Therefore, in the Nb-O solution one would expect the ratio H_n/H_{c3} to be smaller than that observed in Nb.¹¹

In an experiment on varying the degree of segregation at dislocations by (a) quenching, (b) cold working, and (c) strain aging (heating 3 h, 170°C), marked changes

¹¹ J. D. Livingston (private communication).

have been observed in the resistivity in the mixed state between H_{c1} and H_{c2} (see Figs. 16 and 17, Ref. 9) for Nb_{0.993}O_{0.007}. After quenching, $H_{c3}/H_{c2}=1.71$. Cold working the quenched sample increased H_n to approximately 1.8₃ H_{c2} , while strain aging may increase H_n slightly ($H_n \approx 1.8_8 H_{c2}$).

Analysis of I_c data above H_{c2} in terms of J_s may help to elucidate some of the higher values reported for H_{c3} in type II superconductors (e.g., see Ref. 7).

ACKNOWLEDGMENTS

The author wishes to acknowledge the capable assistance of W. A. Healy in the experimental work and to thank C. H. Rosner for the use of the superconducting magnet.

Perturbation Approach to the Diffraction of Electromagnetic Waves by Arbitrarily Shaped Dielectric Obstacles*

C. YEH

Electrical Engineering Department, University of Southern California, Los Angeles, California

(Received 6 March 1964; revised manuscript received 30 April 1964)

A perturbation method is developed to consider the problem of the diffraction of electromagnetic waves by an arbitrarily shaped dielectric obstacle whose boundary may be expressed in the general form, in spherical coordinates, $r_p = r_0[1 + \delta f_1(\theta, \phi) + \delta^2 f_2(\theta, \phi) + \dots]$ where r_0 is the radius of an unperturbed sphere and $f_n(\theta, \phi)$ are arbitrary, single-valued and analytic functions. δ is chosen such that

$$\sum_{n=1}^{\infty} |\delta^n f_n(\theta, \phi)| < 1, \quad 0 \leq \theta \leq \pi, \quad 0 \leq \phi \leq 2\pi.$$

Detailed analysis is carried out to the first order in δ . Procedures to obtain higher order terms are also indicated. The perturbation solutions are valid for the near zone region of the obstacle as well as for the far zone region and they are applicable for all frequencies. Possible applications of this perturbation technique to elementary-particle scattering problems and other electromagnetic scattering problems are noted.

I. INTRODUCTION

THE exact solution of the problem of the diffraction of electromagnetic waves by an obstacle of given shape and electromagnetic properties can be found only in a few cases.^{1,2} For example, the diffraction of waves by a conducting or dielectric sphere, by dielectric coated spheres and by a perfectly conducting disk are the few three-dimensional problems that have been solved rigorously. The need for approximate methods to treat the more general cases of diffraction from arbitrarily shaped obstacles is quite apparent. The variational principles^{3,4} provide a very powerful tool in obtaining

an approximate expression for the scattering cross section; but it is not possible to derive from the variational principles a description of the electromagnetic fields. Furthermore, the success of the variational approach depends to a great extent on the trial function. At low frequencies, the Rayleigh method is very useful.^{5,6} However, the solutions of Laplace's equation are still required. At very high frequencies, the treatment of diffraction problems by geometric and physical optics techniques developed by Fock⁷ and Keller⁸ is very successful. An approximate or perturbation method in the medium frequency range still remains to be found.

* This work was supported by the Air Force Cambridge Research Laboratories.

¹ R. King and T. T. Wu, *The Scattering and Diffraction of Waves* (Harvard University Press, Cambridge, Massachusetts, 1959).

² C. J. Bouwkamp, Rept. Progr. Phys. **17**, 35 (1954).

³ P. M. Morse and H. Feshbach, *Methods of Theoretical Physics* (McGraw-Hill Book Company, Inc., New York, 1953).

⁴ H. Levine and J. Schwinger, *Theory of Electromagnetic Waves* (Interscience Publications, Inc., New York, 1951).

⁵ Lord Rayleigh, Phil. Mag. **44**, 28 (1897).

⁶ A. F. Stevenson, J. Appl. Phys. **24**, 1134 (1953).

⁷ V. A. Fock, J. Phys. (USSR) **10**, 130 (1946); **10**, 399 (1946); see also *Thirteen Papers by V. A. Fock*, edited by N. A. Logan (Antenna Laboratory, Air Force Cambridge Research Center, Bedford, Massachusetts, 1957).

⁸ J. B. Keller, J. Opt. Soc. Am. **52**, 102 (1962).

In this paper, the boundary perturbation technique⁹ will be extended to consider the problem of diffraction of waves by a dielectric object with perturbed boundary. This perturbation method is based on a Taylor expansion of the boundary conditions at the perturbed boundary.¹⁰ Since this approach attacks the complete boundary-value problem, the perturbation solution for the field components is valid for the near zone (i.e., near the obstacle) as well as for the far zone and is valid for all frequencies. Similar procedure has been used recently by Erma¹¹ in his treatment of the electrostatic problem for irregularly shaped conductors.

II. THE PERTURBATION SOLUTION

It is assumed that an arbitrarily shaped dielectric body which has a permittivity ϵ_1 and a permeability μ_1 , is embedded in a homogeneous dielectric medium (ϵ_0, μ_0). The boundary of the dielectric body (Fig. 1) takes the shape of a perturbed sphere which may be expressed by the following equation

$$r_p = r_0(1 + \delta f_1(\theta, \phi) + \delta^2 f_2(\theta, \phi) + \dots), \quad (1a)$$

where r_0 is the radius of the unperturbed sphere, δ is a smallness parameter, and the $f_n(\theta, \phi)$ are arbitrary, single valued, continuous functions satisfying the conditions

$$f_n(\theta, 0) = f_n(\theta, 2\pi); \quad \sum_{n=1}^{\infty} |\delta^n f_n(\theta, \phi)| < 1, \quad (1b)$$

$$0 \leq \theta \leq \pi, \quad 0 \leq \phi \leq 2\pi.$$

The spherical coordinates (r, θ, ϕ) are used.

Let the given exciting field (which need not necessarily be a plane wave) be denoted by $\mathbf{E}^{(i)}$, $\mathbf{H}^{(i)}$, the scattered field by $\mathbf{E}^{(s)}$, $\mathbf{H}^{(s)}$, and the field inside the dielectric body by $\mathbf{E}^{(t)}$, $\mathbf{H}^{(t)}$. The zeroth-order solution will be designated by a subscript 0, the first-order solution by subscript 1, etc. Hence, the resultant scattered fields and the resultant transmitted fields inside the body are respectively,

$$\mathbf{E}^{(s)} = \mathbf{E}_0^{(s)} + \delta \mathbf{E}_1^{(s)} + \delta^2 \mathbf{E}_2^{(s)} + \dots, \quad (2)$$

$$\mathbf{H}^{(s)} = \mathbf{H}_0^{(s)} + \delta \mathbf{H}_1^{(s)} + \delta^2 \mathbf{H}_2^{(s)} + \dots,$$

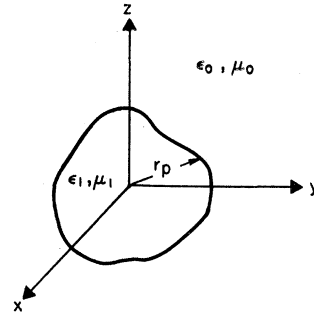

FIG. 1. The arbitrarily shaped dielectric body.

and

$$\mathbf{E}^{(t)} = \mathbf{E}_0^{(t)} + \delta \mathbf{E}_1^{(t)} + \delta^2 \mathbf{E}_2^{(t)} + \dots, \quad (3)$$

$$\mathbf{H}^{(t)} = \mathbf{H}_0^{(t)} + \delta \mathbf{H}_1^{(t)} + \delta^2 \mathbf{H}_2^{(t)} + \dots.$$

The higher order solutions are generated from the known zeroth-order solution; i.e., $\mathbf{E}^{(i)}$, $\mathbf{H}^{(i)}$, $\mathbf{E}_0^{(s)}$, $\mathbf{H}_0^{(s)}$, $\mathbf{E}_0^{(t)}$, and $\mathbf{H}_0^{(t)}$ are assumed known quantities. For the sake of clarity and simplicity, only the first-order solution will be carried out in detail. The higher order solution can be obtained in a similar fashion.

The boundary conditions require the continuity of tangential electric and magnetic fields at the boundary surface $r = r_p$:

$$\mathbf{n} \times [\mathbf{E}^{(i)}(r_p, \theta, \phi) + \mathbf{E}^{(s)}(r_p, \theta, \phi)] = \mathbf{n} \times \mathbf{E}^{(t)}(r_p, \theta, \phi), \quad (4)$$

$$\mathbf{n} \times [\mathbf{H}^{(i)}(r_p, \theta, \phi) + \mathbf{H}^{(s)}(r_p, \theta, \phi)] = \mathbf{n} \times \mathbf{H}^{(t)}(r_p, \theta, \phi), \quad (5)$$

where \mathbf{n} is a unit vector outward normal to the boundary surface and can be written as

$$\mathbf{n} \simeq \mathbf{e}_r - \delta \frac{\partial f_1}{\partial \theta} \mathbf{e}_\theta - \delta \frac{1}{\sin \theta} \frac{\partial f_1}{\partial \phi} \mathbf{e}_\phi, \quad (6)$$

to the first order in δ in spherical coordinates. \mathbf{e}_r , \mathbf{e}_θ , and \mathbf{e}_ϕ are respectively the unit vectors in r , θ , and ϕ directions. f_1 has been defined in Eq. (1). Carrying out the vector operations and expressing Eqs. (4) and (5) to the first order in δ in component form with the help of Eqs. (2) and (3), one obtains

$$\mathbf{e}_r: \quad \delta(\partial f_1 / \partial \theta) [E_\phi^{(i)}(r_p, \theta, \phi) + E_{0\phi}^{(s)}(r_p, \theta, \phi)] + \delta \frac{1}{\sin \theta} \frac{\partial f_1}{\partial \phi} [E_\theta^{(i)}(r_p, \theta, \phi) + E_{0\theta}^{(s)}(r_p, \theta, \phi)]$$

$$= \delta \frac{\partial f_1}{\partial \theta} E_{0\phi}^{(t)}(r_p, \theta, \phi) + \delta \frac{1}{\sin \theta} \frac{\partial f_1}{\partial \phi} E_{0\theta}^{(t)}(r_p, \theta, \phi). \quad (7)$$

$$\mathbf{e}_\theta: \quad E_\phi^{(i)}(r_p, \theta, \phi) + E_{0\phi}^{(s)}(r_p, \theta, \phi) + \delta \left\{ E_{1\phi}^{(s)}(r_p, \theta, \phi) - \frac{1}{\sin \theta} \frac{\partial f_1}{\partial \phi} [E_r^{(i)}(r_p, \theta, \phi) + E_r^{(s)}(r_p, \theta, \phi)] \right\}$$

$$= E_{0\phi}^{(t)}(r_p, \theta, \phi) + \delta \left\{ E_{1\phi}^{(t)}(r_p, \theta, \phi) - \frac{1}{\sin \theta} \frac{\partial f_1}{\partial \phi} E_r^{(t)}(r_p, \theta, \phi) \right\}. \quad (8)$$

⁹ P. M. Morse and H. Feshbach, J. Opt. Soc. Am. **52**, 1052 (1962).

¹⁰ See, for example, P. C. Clemmow and V. H. Weston, Proc. Roy. Soc. (London) **A264**, 246 (1961); C. J. Marcinkowski and L. B. Felsen, J. Res. Natl. Bur. Std. **66D**, 699 (1962); **66D**, 707 (1962).

¹¹ V. A. Erma, J. Math. Phys. **4**, 1517 (1963).

$$\begin{aligned} \mathbf{e}_\phi: \quad & E_\theta^{(i)}(r_p, \theta, \phi) + E_{0\theta}^{(s)}(r_p, \theta, \phi) + \delta \{ E_{1\theta}^{(s)}(r_p, \theta, \phi) + (\partial f_1 / \partial \theta) [E_r^{(i)}(r_p, \theta, \phi) + E_{0r}^{(s)}(r_p, \theta, \phi)] \} \\ & = E_{0\theta}^{(t)}(r_p, \theta, \phi) + \delta \{ E_{1\theta}^{(t)}(r_p, \theta, \phi) + (\partial f_1 / \partial \theta) E_{0r}^{(t)}(r_p, \theta, \phi) \}. \end{aligned} \quad (9)$$

$$\begin{aligned} \mathbf{e}_r: \quad & \delta (\partial f_1 / \partial \theta) [H_\phi^{(i)}(r_p, \theta, \phi) + H_{0\phi}^{(s)}(r_p, \theta, \phi)] + \delta \frac{1}{\sin \theta} \frac{\partial f_1}{\partial \phi} [H_\theta^{(i)}(r_p, \theta, \phi) + H_{0\theta}^{(s)}(r_p, \theta, \phi)] \\ & = \delta \frac{\partial f_1}{\partial \theta} H_{0\phi}^{(t)}(r_p, \theta, \phi) + \delta \frac{1}{\sin \theta} \frac{\partial f_1}{\partial \phi} H_{0\theta}^{(t)}(r_p, \theta, \phi). \end{aligned} \quad (10)$$

$$\begin{aligned} \mathbf{e}_\theta: \quad & H_\phi^{(i)}(r_p, \theta, \phi) + H_{0\phi}^{(s)}(r_p, \theta, \phi) + \delta \left\{ H_{1\phi}^{(s)}(r_p, \theta, \phi) - \frac{1}{\sin \theta} \frac{\partial f_1}{\partial \phi} [H_r^{(i)}(r_p, \theta, \phi) + H_{0r}^{(s)}(r_p, \theta, \phi)] \right\} \\ & = H_{0\phi}^{(t)}(r_p, \theta, \phi) + \delta \left\{ H_{1\phi}^{(t)}(r_p, \theta, \phi) - \frac{1}{\sin \theta} \frac{\partial f_1}{\partial \phi} H_{0r}^{(t)}(r_p, \theta, \phi) \right\}. \end{aligned} \quad (11)$$

$$\begin{aligned} \mathbf{e}_\theta: \quad & H_\theta^{(i)}(r_p, \theta, \phi) + H_{0\theta}^{(s)}(r_p, \theta, \phi) + \delta \{ H_{1\theta}^{(s)}(r_p, \theta, \phi) + (\partial f_1 / \partial \theta) [H_r^{(i)}(r_p, \theta, \phi) + H_{0r}^{(s)}(r_p, \theta, \phi)] \} \\ & = H_{0\theta}^{(t)}(r_p, \theta, \phi) + \delta \{ H_{1\theta}^{(t)}(r_p, \theta, \phi) + (\partial f_1 / \partial \theta) H_{0r}^{(t)}(r_p, \theta, \phi) \}. \end{aligned} \quad (12)$$

Equations (7) and (10) are satisfied by the zeroth-order solution. We now expand the above functions in Eqs. (8), (9), (11), and (12) to order δ in Taylor series about the unperturbed boundary $r=r_0$, obtaining

$$\begin{aligned} & E_\phi^{(i)}(r_0, \theta, \phi) + E_{0\phi}^{(s)}(r_0, \theta, \phi) - E_{0\phi}^{(t)}(r_0, \theta, \phi) \\ & = \delta \left\{ \frac{1}{\sin \theta} \frac{\partial f_1}{\partial \phi} [E_r^{(i)}(r_0, \theta, \phi) + E_{0r}^{(s)}(r_0, \theta, \phi)] - E_{1\phi}^{(s)}(r_0, \theta, \phi) - r_0 f_1 [E_\phi^{(i)'}(r_0, \theta, \phi) + E_{0\phi}^{(s)'}(r_0, \theta, \phi)] \right\} \\ & \quad - \delta \left\{ \frac{1}{\sin \theta} \frac{\partial f_1}{\partial \phi} E_{0r}^{(t)}(r_0, \theta, \phi) - E_{1\phi}^{(t)}(r_0, \theta, \phi) - r_0 f_1 E_{0\phi}^{(t)'}(r_0, \theta, \phi) \right\}, \end{aligned} \quad (13)$$

$$\begin{aligned} & E_\theta^{(i)}(r_0, \theta, \phi) + E_{0\theta}^{(s)}(r_0, \theta, \phi) - E_{0\theta}^{(t)}(r_0, \theta, \phi) \\ & = -\delta \{ E_{1\theta}^{(s)}(r_0, \theta, \phi) + (\partial f_1 / \partial \theta) [E_r^{(i)}(r_0, \theta, \phi) + E_{0r}^{(s)}(r_0, \theta, \phi)] + r_0 f_1 [E_\theta^{(i)'}(r_0, \theta, \phi) + E_{0\theta}^{(s)'}(r_0, \theta, \phi)] \} \\ & \quad + \delta \{ E_{1\theta}^{(t)}(r_0, \theta, \phi) + (\partial f_1 / \partial \theta) E_{0r}^{(t)}(r_0, \theta, \phi) + r_0 f_1 E_{0\theta}^{(t)'}(r_0, \theta, \phi) \}, \end{aligned} \quad (14)$$

$$\begin{aligned} & H_\phi^{(i)}(r_0, \theta, \phi) + H_{0\phi}^{(s)}(r_0, \theta, \phi) - H_{0\phi}^{(t)}(r_0, \theta, \phi) \\ & = \delta \left\{ \frac{1}{\sin \theta} \frac{\partial f_1}{\partial \phi} [H_r^{(i)}(r_0, \theta, \phi) + H_{0r}^{(s)}(r_0, \theta, \phi)] - H_{1\phi}^{(s)}(r_0, \theta, \phi) - r_0 f_1 [H_\phi^{(i)'}(r_0, \theta, \phi) + H_{0\phi}^{(s)'}(r_0, \theta, \phi)] \right\} \\ & \quad - \delta \left\{ \frac{1}{\sin \theta} \frac{\partial f_1}{\partial \phi} H_{0r}^{(t)}(r_0, \theta, \phi) - H_{1\phi}^{(t)}(r_0, \theta, \phi) - r_0 f_1 H_{0\phi}^{(t)'}(r_0, \theta, \phi) \right\}, \end{aligned} \quad (15)$$

$$\begin{aligned} & H_\theta^{(i)}(r_0, \theta, \phi) + H_{0\theta}^{(s)}(r_0, \theta, \phi) - H_{0\theta}^{(t)}(r_0, \theta, \phi) \\ & = -\delta \{ H_{1\theta}^{(s)}(r_0, \theta, \phi) + (\partial f_1 / \partial \theta) [H_r^{(i)}(r_0, \theta, \phi) + H_{0r}^{(s)}(r_0, \theta, \phi)] + r_0 f_1 [H_\theta^{(i)'}(r_0, \theta, \phi) + H_{0\theta}^{(s)'}(r_0, \theta, \phi)] \} \\ & \quad + \delta \{ H_{1\theta}^{(t)}(r_0, \theta, \phi) + (\partial f_1 / \partial \theta) H_{0r}^{(t)}(r_0, \theta, \phi) + r_0 f_1 H_{0\theta}^{(t)'}(r_0, \theta, \phi) \}, \end{aligned} \quad (16)$$

where the prime signified the derivative of the function with respect to r_0 . The left-hand sides of the above equations are equal to zero by virtue of the zeroth-order solution. Hence, the right-hand sides of the above equations must vanish identically. Rearranging and combining Eqs. (13) and (14) gives

$$[E_{1\theta}^{(s)}(r_0, \theta, \phi) - E_{1\theta}^{(t)}(r_0, \theta, \phi)] \mathbf{e}_\theta + [E_{1\phi}^{(s)}(r_0, \theta, \phi) - E_{1\phi}^{(t)}(r_0, \theta, \phi)] \mathbf{e}_\phi = u_1(r_0, \theta, \phi) \mathbf{e}_\theta + u_2(r_0, \theta, \phi) \mathbf{e}_\phi, \quad (17)$$

and combining Eqs. (15) and (16) gives

$$[H_{1\theta}^{(s)}(r_0, \theta, \phi) - H_{1\theta}^{(t)}(r_0, \theta, \phi)] \mathbf{e}_\theta + [H_{1\phi}^{(s)}(r_0, \theta, \phi) - H_{1\phi}^{(t)}(r_0, \theta, \phi)] \mathbf{e}_\phi = v_1(r_0, \theta, \phi) \mathbf{e}_\theta + v_2(r_0, \theta, \phi) \mathbf{e}_\phi, \quad (18)$$

where

$$\begin{aligned}
 u_1(r_0, \theta, \phi) &= (\partial f_1 / \partial \theta) [E_{0r}^{(t)}(r_0, \theta, \phi) - E_r^{(i)}(r_0, \theta, \phi) - E_{0r}^{(s)}(r_0, \theta, \phi)] \\
 &\quad + r_0 f_1 [E_{0\theta}^{(t)'}(r_0, \theta, \phi) - E_\theta^{(i)'}(r_0, \theta, \phi) - E_{0\theta}^{(s)'}(r_0, \theta, \phi)], \\
 u_2(r_0, \theta, \phi) &= \frac{1}{\sin \theta} \frac{\partial f_1}{\partial \phi} [E_r^{(i)}(r_0, \theta, \phi) + E_{0r}^{(s)}(r_0, \theta, \phi) - E_{0r}^{(t)}(r_0, \theta, \phi)] \\
 &\quad + r_0 f_1 [E_{0\phi}^{(t)'}(r_0, \theta, \phi) - E_\phi^{(i)'}(r_0, \theta, \phi) - E_{0\phi}^{(s)'}(r_0, \theta, \phi)], \quad (19) \\
 v_1(r_0, \theta, \phi) &= (\partial f_1 / \partial \theta) [H_{0r}^{(t)}(r_0, \theta, \phi) - H_r^{(i)}(r_0, \theta, \phi) - H_{0r}^{(s)}(r_0, \theta, \phi)] \\
 &\quad + r_0 f_1 [H_{0\theta}^{(t)'}(r_0, \theta, \phi) - H_\theta^{(i)'}(r_0, \theta, \phi) - H_{0\theta}^{(s)'}(r_0, \theta, \phi)], \\
 v_2(r_0, \theta, \phi) &= \frac{1}{\sin \theta} \frac{\partial f_1}{\partial \phi} [H_r^{(i)}(r_0, \theta, \phi) + H_{0r}^{(s)}(r_0, \theta, \phi) - H_{0r}^{(t)}(r_0, \theta, \phi)] \\
 &\quad + r_0 f_1 [H_{0\phi}^{(t)'}(r_0, \theta, \phi) - H_\phi^{(i)'}(r_0, \theta, \phi) - H_{0\phi}^{(s)'}(r_0, \theta, \phi)].
 \end{aligned}$$

It is noted that the resultant fields given by Eqs. (2) and (3) must satisfy the wave equation. It is therefore clear that each term in Eqs. (2) and (3) must separately satisfy the wave equation. Consequently, the general expressions for $\mathbf{E}_1^{(s)}$, $\mathbf{H}_1^{(s)}$, $\mathbf{E}_1^{(t)}$, and $\mathbf{H}_1^{(t)}$, that are appropriate to the present problem, are¹²

$$\mathbf{E}_1^{(s)} = \sum_{m,n} A_{e,omn} \mathbf{M}_{e,omn}^{(s)} + B_{e,omn} \mathbf{N}_{e,omn}^{(s)}, \quad (20)$$

$$\mathbf{H}_1^{(s)} = \sum_{m,n} \frac{k_0}{i\omega\mu_0} (A_{e,omn} \mathbf{N}_{e,omn}^{(s)} + B_{e,omn} \mathbf{M}_{e,omn}^{(s)}), \quad (21)$$

$$\mathbf{E}_1^{(t)} = \sum_{m,n} C_{e,omn} \mathbf{M}_{e,omn}^{(t)} + D_{e,omn} \mathbf{N}_{e,omn}^{(t)}, \quad (22)$$

$$\mathbf{H}_1^{(t)} = \sum_{m,n} \frac{k_1}{i\omega\mu_1} (C_{e,omn} \mathbf{N}_{e,omn}^{(t)} + D_{e,omn} \mathbf{M}_{e,omn}^{(t)}), \quad (23)$$

where

$$\begin{aligned}
 \mathbf{M}_{e,omn}^{(s)} &= h_n^{(1)}(k_0 r) \mathbf{m}_{e,omn}, \\
 \mathbf{N}_{e,omn}^{(s)} &= \frac{1}{k_0 r} h_n^{(1)}(k_0 r) \mathbf{l}_{e,omn} + \frac{1}{k_0 r} \frac{\partial}{\partial r} [r h_n^{(1)}(k_0 r)] (\mathbf{e}_r \times \mathbf{m}_{e,omn}), \\
 \mathbf{M}_{e,omn}^{(t)} &= j_n(k_1 r) \mathbf{m}_{e,omn}, \\
 \mathbf{N}_{e,omn}^{(t)} &= \frac{1}{k_1 r} j_n(k_1 r) \mathbf{l}_{e,omn} + \frac{1}{k_1 r} \frac{\partial}{\partial r} [r j_n(k_1 r)] (\mathbf{e}_r \times \mathbf{m}_{e,omn}),
 \end{aligned} \quad (24)$$

with

$$\begin{aligned}
 \mathbf{m}_{e,omn} &= \mp \frac{m P_n^m(\cos \theta)}{\sin \theta} \frac{\sin}{\cos} m \phi \mathbf{e}_\theta - \frac{\partial P_n^m(\cos \theta)}{\partial \theta} \frac{\cos}{\sin} m \phi \mathbf{e}_\phi, \\
 \mathbf{l}_{e,omn} &= n(n+1) P_n^m(\cos \theta) \frac{\cos}{\sin} m \phi \mathbf{e}_r.
 \end{aligned} \quad (25)$$

$h_n^{(1)}(k_0 r)$ and $j_n(k_1 r)$ are, respectively, spherical Hankel and spherical Bessel functions; $P_n^m(\cos \theta)$ are associated Legendre polynomials. $k_0^2 = \omega^2 \mu_0 \epsilon_0$ and $k_1^2 = \omega^2 \mu_1 \epsilon_1$. $A_{e,omn}$, $B_{e,omn}$, $C_{e,omn}$ and $D_{e,omn}$ are yet unknown arbitrary constants that can be determined from Eqs. (17) and (18) using the orthogonality properties of the angular

¹² J. A. Stratton, *Electromagnetic Theory* (McGraw-Hill Book Company, Inc., New York, 1941).

functions. Substituting Eqs. (20) through (23) into Eqs. (17) and (18), and making use of the following orthogonality relations

$$\begin{aligned} \mathbf{l}_{e,omn} \cdot \mathbf{m}_{e,omn} &= 0, \quad \mathbf{l}_{e,omn} \cdot (\mathbf{e}_r \times \mathbf{m}_{e,omn}) = 0, \quad \mathbf{m}_{e,omn} \cdot (\mathbf{e}_r \times \mathbf{m}_{e,omn}) = 0, \\ \int_0^\pi \int_0^{2\pi} (\mathbf{l}_{e,omn} \cdot \mathbf{l}_{e,om'n'}) \sin\theta d\theta d\phi &= \begin{cases} 0, & \text{for } m \neq m', n \neq n' \\ \frac{2n^2(n+1)^2}{2n+1} \frac{(n+m)!}{(n-m)!} (1+\delta_{0m})\pi & \text{for } m = m', n = n', \end{cases} \\ \int_0^\pi \int_0^{2\pi} (\mathbf{m}_{e,omn} \cdot \mathbf{m}_{e,om'n'}) \sin\theta d\theta d\phi &= \int_0^\pi \int_0^{2\pi} [(\mathbf{e}_r \times \mathbf{m}_{e,omn}) \cdot (\mathbf{e}_r \times \mathbf{m}_{e,om'n'})] \sin\theta d\theta d\phi \\ &= \begin{cases} 0, & \text{for } m \neq m', n \neq n' \\ \frac{2n(n+1)}{2n+1} \frac{(n+m)!}{(n-m)!} (1+\delta_{0m})\pi, & \text{for } m = m', n = n', \end{cases} \\ \delta_{0m} &= \begin{cases} 1, & m=0 \\ 0, & m>0, \end{cases} \end{aligned} \quad (26)$$

one obtains

$$A_{e,omn} h_n^{(1)}(k_0 r_0) - C_{e,omn} j_n(k_1 r_0) = \frac{1}{\dot{p}_{mn}} \int_0^\pi \int_0^{2\pi} \mathbf{u} \cdot \mathbf{m}_{e,omn} \sin\theta d\theta d\phi, \quad (27)$$

$$B_{e,omn} \frac{1}{k_0 r_0} \frac{\partial}{\partial r_0} [r_0 h_n^{(1)}(k_0 r_0)] - D_{e,omn} \frac{1}{k_1 r_0} \frac{\partial}{\partial r_0} [r_0 j_n(k_1 r_0)] = \frac{1}{\dot{p}_{mn}} \int_0^\pi \int_0^{2\pi} \mathbf{u} \cdot (\mathbf{e}_r \times \mathbf{m}_{e,omn}) \sin\theta d\theta d\phi, \quad (28)$$

$$A_{e,omn} \frac{1}{i\omega\mu_0 r_0} \frac{\partial}{\partial r_0} [r_0 h_n^{(1)}(k_0 r_0)] - C_{e,omn} \frac{1}{i\omega\mu_1 r_0} \frac{\partial}{\partial r_0} [r_0 j_n(k_1 r_0)] = \frac{1}{\dot{p}_{mn}} \int_0^\pi \int_0^{2\pi} \mathbf{v} \cdot (\mathbf{e}_r \times \mathbf{m}_{e,omn}) \sin\theta d\theta d\phi, \quad (29)$$

$$B_{e,omn} \frac{k_0}{i\omega\mu_0} h_n^{(1)}(k_0 r_0) - D_{e,omn} \frac{k_1}{i\omega\mu_1} j_n(k_1 r_0) = \frac{1}{\dot{p}_{mn}} \int_0^\pi \int_0^{2\pi} \mathbf{v} \cdot \mathbf{m}_{e,omn} \sin\theta d\theta d\phi, \quad (30)$$

with

$$\mathbf{u} = u_1(r_0, \theta, \phi) \mathbf{e}_\theta + u_2(r_0, \theta, \phi) \mathbf{e}_\phi, \quad (31)$$

$$\mathbf{v} = v_1(r_0, \theta, \phi) \mathbf{e}_\theta + v_2(r_0, \theta, \phi) \mathbf{e}_\phi, \quad (32)$$

$$\dot{p}_{mn} = \frac{2n+1}{2n(n+1)} \frac{(n-m)!}{(n+m)!} \frac{1}{(1+\delta_{0m})\pi}. \quad (33)$$

u_1 , u_2 , v_1 , and v_2 are given by Eq. (19). The coefficients $A_{e,omn}$, $B_{e,omn}$, $C_{e,omn}$, and $D_{e,omn}$ can be found readily from the above equations. Substituting these coefficients back to Eqs. (20) through (23) gives the first-order correction to the electromagnetic fields due to the departure of the boundary surface from a perfect sphere with radius r_0 . Higher order corrections can be found successively in the same manner. It is interesting to note from the above analysis that, in general, the perturbed wave will have all components of electromagnetic fields even if the incident wave is a pure TE wave ($E_r^{(i)} = 0$) or a pure TM wave ($H_r^{(i)} = 0$).

Since the exact solution to the problem of the diffraction of electromagnetic waves by a three-dimensional dielectric obstacle other than a sphere is not available, it is therefore not possible to compare the result obtained by the above perturbation approach

with a known one. However, as a partial check, the problem of the diffraction of a plane wave by a dielectric sphere of radius $r_0(1+\delta)$ was carried out in detail using the above derived formulas. Results are found to be in complete agreement with the solutions obtained by expanding the exact solutions to the first order in δ .

III. AN EXAMPLE: THE SCATTERING OF PLANE WAVES BY A DIELECTRIC SPHEROID

As a less trivial example of the application of the theory derived in Sec. II, the problem of the scattering of plane waves by a dielectric spheroid with small eccentricity will be considered. It is assumed that the incident plane wave with its electric vector polarized in the x direction is propagating in the direction of the negative z axis. The equation of a spheroidal surface is given by

$$r_p = r_0 [(1 - 2\delta \sin^2 \theta)^{1/2}], \quad (34)$$

where

$$\delta = [1 - (r_0 / (r_0 + \Delta r_0))^2] \quad (35)$$

($\delta < 0$: prolate spheroid; $\delta > 0$: oblate spheroid), and $2r_0$ and $2(r_0 + \Delta r_0)$ are the lengths of the two axes of the

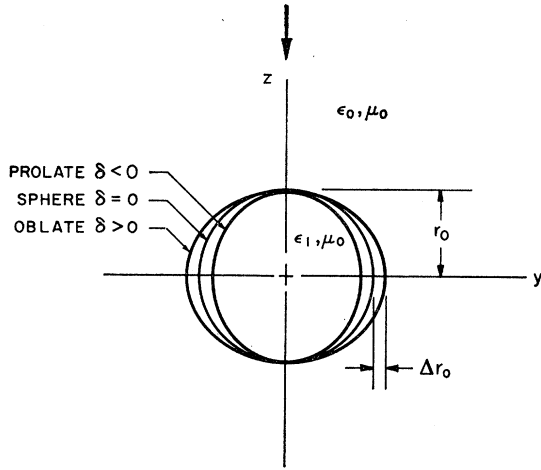

FIG. 2. The dielectric spheroid. The arrow indicates the direction of the incident wave.

spheroid. (See Fig. 2.) For small eccentricity, one has

$$r_p \approx r_0 [1 + \delta \sin^2 \theta]. \tag{36}$$

Comparing Eqs. (36) and (1a) gives

$$f_1(\theta, \phi) = \sin^2 \theta. \tag{37}$$

with

$$a_n^s = \frac{\mu_0 j_n(k_0 r_0) [k_1 r_0 j_n(k_1 r_0)]' - \mu_1 j_n(k_1 r_0) [k_0 r_0 j_n(k_0 r_0)]'}{\mu_1 j_n(k_1 r_0) [k_0 r_0 h_n^{(1)}(k_0 r_0)]' - \mu_0 h_n^{(1)}(k_0 r_0) [k_1 r_0 j_n(k_1 r_0)]'}, \tag{41a}$$

$$b_n^s = \frac{(k_0/k_1)^2 \mu_1 j_n(k_0 r_0) [k_1 r_0 j_n(k_1 r_0)]' - \mu_0 j_n(k_1 r_0) [k_0 r_0 j_n(k_0 r_0)]'}{\mu_0 j_n(k_0 r_0) [k_0 r_0 h_n^{(1)}(k_0 r_0)]' - \mu_1 (k_0/k_1)^2 h_n^{(1)}(k_0 r_0) [k_1 r_0 j_n(k_1 r_0)]'}, \tag{41b}$$

$$a_n^t = \frac{(-i) \mu_1 / k_0 r_0}{\mu_0 h_n^{(1)}(k_0 r_0) [k_1 r_0 j_n(k_1 r_0)]' - \mu_1 j_n(k_1 r_0) [k_0 r_0 h_n^{(1)}(k_0 r_0)]'}, \tag{42a}$$

$$b_n^t = \frac{(-i) \mu_1 k_1 r_0}{\mu_1 (k_0 r_0)^2 h_n^{(1)}(k_0 r_0) [k_1 r_0 j_n(k_1 r_0)]' - \mu_0 (k_1 r_0)^2 j_n(k_1 r_0) [k_0 r_0 h_n^{(1)}(k_0 r_0)]'}. \tag{42b}$$

$\mathbf{M}_{e,omn}^{(1)}$ and $\mathbf{N}_{e,omn}^{(1)}$ are obtained, respectively, by replacing $h_n^{(1)}(k_0 r)$ by $j_n(k_0 r)$ in $\mathbf{M}_{e,omn}^{(s)}$ and $\mathbf{N}_{e,omn}^{(s)}$. The prime in the above expressions denotes differentiation with respect to $k_0 r_0$ or $k_1 r_0$ as appropriate.

To find the first-order perturbation solution, we first substitute Eqs. (38) through (40) into Eq. (19) obtaining

$$u_1(r_0, \theta, \phi) = \sum_{p=1}^{\infty} (-i)^p \frac{2p+1}{p(p+1)} \left[P_p \frac{\partial f_1}{\partial \theta} (\mathbf{l}_{e1p} \cdot \mathbf{e}_r) + Q_p f_1 (\mathbf{m}_{e1p} \cdot \mathbf{e}_\theta) + R_p f_1 ((\mathbf{e}_r \times \mathbf{m}_{e1p}) \cdot \mathbf{e}_\theta) \right], \tag{43}$$

$$u_2(r_0, \theta, \phi) = \sum_{p=1}^{\infty} (-i)^p \frac{2p+1}{p(p+1)} [Q_p f_1 (\mathbf{m}_{e1p} \cdot \mathbf{e}_\phi) + R_p f_1 ((\mathbf{e}_r \times \mathbf{m}_{e1p}) \cdot \mathbf{e}_\phi)], \tag{44}$$

$$v_1(r_0, \theta, \phi) = \sum_{p=1}^{\infty} (-i)^p \frac{2p+1}{p(p+1)} \frac{k_0}{i\omega\mu_0} \left[S_p \frac{\partial f_1}{\partial \theta} (\mathbf{l}_{e1p} \cdot \mathbf{e}_r) + T_p f_1 ((\mathbf{e}_r \times \mathbf{m}_{e1p}) \cdot \mathbf{e}_\theta) + U_p f_1 (\mathbf{m}_{e1p} \cdot \mathbf{e}_\theta) \right], \tag{45}$$

$$v_2(r_0, \theta, \phi) = \sum_{p=1}^{\infty} (-i)^p \frac{2p+1}{p(p+1)} \frac{k_0}{i\omega\mu_0} [T_p f_1 ((\mathbf{e}_r \times \mathbf{m}_{e1p}) \cdot \mathbf{e}_\phi) + U_p f_1 (\mathbf{m}_{e1p} \cdot \mathbf{e}_\phi)], \tag{46}$$

The unperturbed solution to the problem of the scattering of plane waves by a dielectric sphere is well known¹²:

$$\mathbf{E}^{(i)} = \sum_{n=1}^{\infty} (-i)^n \frac{2n+1}{n(n+1)} (\mathbf{M}_{e1n}^{(1)} + i \mathbf{N}_{e1n}^{(1)}), \tag{38a}$$

$$\mathbf{H}^{(i)} = \sum_{n=1}^{\infty} \frac{k_0}{i\omega\mu_0} (-i)^n \frac{2n+1}{n(n+1)} (\mathbf{N}_{e1n}^{(1)} + i \mathbf{M}_{e1n}^{(1)}), \tag{38b}$$

$$\mathbf{E}_0^{(s)} = \sum_{n=1}^{\infty} (-i)^n \frac{2n+1}{n(n+1)} (a_n^s \mathbf{M}_{e1n}^{(s)} + i b_n^s \mathbf{N}_{e1n}^{(s)}), \tag{39a}$$

$$\mathbf{H}_0^{(s)} = \sum_{n=1}^{\infty} \frac{k_0}{i\omega\mu_0} (-i)^n \frac{2n+1}{n(n+1)} (a_n^s \mathbf{N}_{e1n}^{(s)} + i b_n^s \mathbf{M}_{e1n}^{(s)}), \tag{39b}$$

$$\mathbf{E}_0^{(t)} = \sum_{n=1}^{\infty} (-i)^n \frac{2n+1}{n(n+1)} (a_n^t \mathbf{M}_{e1n}^{(t)} + i b_n^t \mathbf{N}_{e1n}^{(t)}), \tag{40a}$$

$$\mathbf{H}_0^{(t)} = \sum_{n=1}^{\infty} \frac{k_0}{i\omega\mu_0} (-i)^n \frac{2n+1}{n(n+1)} \times (a_n^t \mathbf{N}_{e1n}^{(t)} + i b_n^t \mathbf{M}_{e1n}^{(t)}), \tag{40b}$$

where

$$P_p = (i/k_0 r_0) [b_p^t(k_0/k_1) j_p(k_1 r_0) - j_p(k_0 r_0) - b_p^s h_p^{(1)}(k_0 r_0)], \quad (47)$$

$$Q_p = a_p^t k_1 r_0 j_p'(k_1 r_0) - k_0 r_0 j_p'(k_0 r_0) - a_p^s k_0 r_0 h_p^{(1)'}(k_0 r_0), \quad (48)$$

$$R_p = i k_1 r_0 b_p^t [(1/k_1 r_0) (k_1 r_0 j_p(k_1 r_0))']' - i k_0 r_0 [(1/k_0 r_0) (k_0 r_0 j_p(k_0 r_0))']' - i k_0 r_0 b_p^s [(1/k_0 r_0) (k_0 r_0 h_p^{(1)}(k_0 r_0))']', \quad (49)$$

$$S_p = (k_1 \mu_0/k_0 \mu_1) (1/k_1 r_0) a_p^t j_p(k_1 r_0) - (1/k_0 r_0) j_p(k_0 r_0) - (1/k_0 r_0) a_p^s h_p^{(1)}(k_0 r_0), \quad (50)$$

$$T_p = (k_1 \mu_0/k_0 \mu_1) a_p^t k_1 r_0 [(1/k_1 r_0) (k_1 r_0 j_p(k_1 r_0))']' - k_0 r_0 [(1/k_0 r_0) (k_0 r_0 j_p(k_0 r_0))']' - a_p^s k_0 r_0 [(1/k_0 r_0) (k_0 r_0 h_p^{(1)}(k_0 r_0))']', \quad (51)$$

$$U_p = i(k_1 \mu_0/k_0 \mu_1) b_p^t k_1 r_0 j_n'(k_1 r_0) - i k_0 r_0 j_n'(k_0 r_0) - i b_n^s k_0 r_0 h_n^{(1)'}(k_0 r_0). \quad (52)$$

The expansion coefficients for the first-order perturbation fields are then found by putting expressions (43) through (46) into Eqs. (27) through (30) and carrying out the integration where possible. One has

$$\begin{aligned} A_{emn} &= B_{omn} = C_{emn} = D_{omn} = 0 \quad \text{for all } m \text{ and } n, \\ A_{omn} &= B_{emn} = C_{omn} = D_{emn} = 0 \quad \text{for } m \neq 1 \text{ and all } n, \\ A_{o1n} &= [\chi_{o1n} j_n(k_1 r_0) - \alpha_{o1n} (k_1 \mu_0/k_0 \mu_1) (1/k_1 r_0) (k_1 r_0 j_n(k_1 r_0))'] / \Gamma, \\ B_{e1n} &= [-\gamma_{e1n} (1/k_1 r_0) (k_1 r_0 j_n(k_1 r_0))' + \beta_{e1n} (k_1 \mu_0/k_0 \mu_1) j_n(k_1 r_0)] (k_0 \mu_1/k_1 \mu_0) / \Gamma, \\ C_{o1n} &= [\chi_{o1n} h_n^{(1)}(k_0 r_0) - \alpha_{o1n} (1/k_0 r_0) (k_0 r_0 h_n^{(1)}(k_0 r_0))'] / \Gamma, \\ D_{e1n} &= [-\beta_{e1n} h_n^{(1)}(k_0 r_0) + \gamma_{e1n} (1/k_0 r_0) (k_0 r_0 h_n^{(1)}(k_0 r_0))'] (k_0 \mu_1/k_1 \mu_0) / \Gamma, \end{aligned} \quad (53)$$

with

$$\begin{aligned} \Gamma &= (1/k_0 r_0) (k_0 r_0 h_n^{(1)}(k_0 r_0))' j_n(k_1 r_0) - (k_1 \mu_0/k_0 \mu_1) (1/k_1 r_0) (k_1 r_0 j_n(k_1 r_0))' h_n^{(1)}(k_0 r_0), \\ \alpha_{o1n} &= \frac{\pi}{p_{1n}} \sum_{p=1}^{\infty} (-i)^p \frac{2p+1}{p(p+1)} [P_p J_{11n^p} + Q_p J_{21n^p} + R_p J_{31n^p}], \\ \beta_{e1n} &= \frac{\pi}{p_{1n}} \sum_{p=1}^{\infty} (-i)^p \frac{2p+1}{p(p+1)} [P_p J_{41n^p} + Q_p J_{31n^p} + R_p J_{21n^p}], \\ \gamma_{e1n} &= \frac{\pi}{p_{1n}} \sum_{p=1}^{\infty} (-i)^p \frac{2p+1}{p(p+1)} [S_p J_{11n^p} + T_p J_{31n^p} + U_p J_{21n^p}], \\ \chi_{o1n} &= \frac{\pi}{p_{1n}} \sum_{p=1}^{\infty} (-i)^p \frac{2p+1}{p(p+1)} [S_p J_{41n^p} + T_p J_{21n^p} + U_p J_{31n^p}], \end{aligned} \quad (54)$$

where J_{11n^p} , J_{21n^p} , J_{31n^p} , and J_{41n^p} , which are definite integrals involving the associated Legendre functions, are given in the Appendix. Hence, the scattered fields correct to the first order in δ are

$$\mathbf{E}^{(s)} = \sum_{n=1}^{\infty} \left[(-i)^n \frac{2n+1}{n(n+1)} a_n^s + \delta A_{o1n} \right] \mathbf{M}_{o1n}^{(s)} + \left[i(-i)^n \frac{2n+1}{n(n+1)} b_n^s + \delta B_{e1n} \right] \mathbf{N}_{e1n}^{(s)}, \quad (55)$$

$$\mathbf{H}^{(s)} = \sum_{n=1}^{\infty} \frac{k_0}{i\omega\mu_0} \left\{ \left[(-i)^n \frac{2n+1}{n(n+1)} a_n^s + \delta A_{o1n} \right] \mathbf{N}_{o1n}^{(s)} + \left[i(-i)^n \frac{2n+1}{n(n+1)} b_n^s + \delta B_{e1n} \right] \mathbf{M}_{e1n}^{(s)} \right\}. \quad (56)$$

Of particular interest is the far zone behavior of the scattered field. The radial component of the scattered field may be neglected at large r because of its rapid fall off compared to the θ or ϕ component. Consequently, the scattered field has the form of a spherically outgoing wave, i.e.,

$$\mathbf{E}^{(s)} \sim \frac{e^{ik_0 r}}{k_0 r} \sum_{n=1}^{\infty} (-i)^{n+1} \left\{ \left[V_n \frac{P_n^1(\cos\theta)}{\sin\theta} - iW_n \frac{\partial}{\partial\theta} P_n^1(\cos\theta) \right] \cos\phi \mathbf{e}_\theta - \left[V_n \frac{\partial}{\partial\theta} P_n^1(\cos\theta) - iW_n \frac{P_n^1(\cos\theta)}{\sin\theta} \right] \sin\phi \mathbf{e}_\phi \right\}, \quad (57)$$

where

$$V_n = (-i)^n [(2n+1)/n(n+1)] a_n^s + \delta A_{o1n}, \quad (58)$$

$$W_n = i(-i)^n [(2n+1)/n(n+1)] b_n^s + \delta B_{e1n}. \quad (59)$$

Rewriting Eq. (57) gives

$$\mathbf{E}^{(s)} \sim E_\theta^{(s)} \mathbf{e}_\theta + E_\phi^{(s)} \mathbf{e}_\phi, \quad (60)$$

with

$$E_\theta^{(s)} = (e^{ik_0 r}/k_0 r) \cos\phi S_1(\theta), \quad (61)$$

$$E_\phi^{(s)} = -(e^{ik_0 r}/k_0 r) \sin\phi S_2(\theta), \quad (62)$$

where $S_1(\theta)$ and $S_2(\theta)$ are called the complex amplitudes of the scattered radiation for the two polarizations. The squares of the absolute values of $S_1(\theta)$ and $S_2(\theta)$ are called the intensities of the scattered radiation for the two polarizations; i.e.,

$$I_\theta = |S_1(\theta)|^2, \quad \text{and} \quad I_\phi = |S_2(\theta)|^2. \quad (63)$$

The backscattering cross section or the radar cross section is also of interest. It is defined by

$$\sigma = \lim_{r \rightarrow \infty} 4\pi r^2 |E^s|^2 / |E^i|^2 |_{\theta=0^\circ}, \quad (64)$$

or from Eq. (57),

$$\sigma = \frac{4\pi}{k_0^2} \left| \sum_{n=1}^{\infty} (-i)^{n+1} \frac{n(n+1)}{2} (V_n - iW_n) \right|^2. \quad (65)$$

Simplifying gives

$$\begin{aligned} \sigma \simeq & \frac{4\pi}{k_0^2} \left\{ \left| \sum_{n=1}^{\infty} (-1)^n \frac{2n+1}{2} (-i)(a_n^s + b_n^s) \right|^2 \right. \\ & + \delta \left[\left(\sum_{n=1}^{\infty} (-1)^n \frac{2n+1}{2} (-i)(a_n^s + b_n^s) \right) \right. \\ & \times \left(\sum_{n=1}^{\infty} (-i)^{n+1} \frac{n(n+1)}{2} (A_{o1n} - iB_{e1n}) \right)^* \\ & \left. + \left(\sum_{n=1}^{\infty} (-1)^n \frac{2n+1}{2} (-i)(a_n^s + b_n^s) \right)^* \right. \\ & \left. \times \left(\sum_{n=1}^{\infty} (-i)^{n+1} \frac{n(n+1)}{2} (A_{o1n} - iB_{e1n}) \right) \right] \left. \right\}, \quad (66) \end{aligned}$$

where the asterisk indicates the complex conjugate of the function. The first term on the right-hand side of the above equation represents the backscattering cross section of an unperturbed sphere, while the other term corresponds to the first-order correction due to small eccentricity.

To qualitatively illustrate how the solutions behave, numerical computations are carried out using the high-speed IBM-7094 computer. It is assumed that $(\epsilon_1/\epsilon_0)^{1/2} = 1.33$ and $\mu_1/\mu_0 = 1.0$. The Bessel functions and associated Legendre functions are computed from available subroutines. The integrals in the Appendix

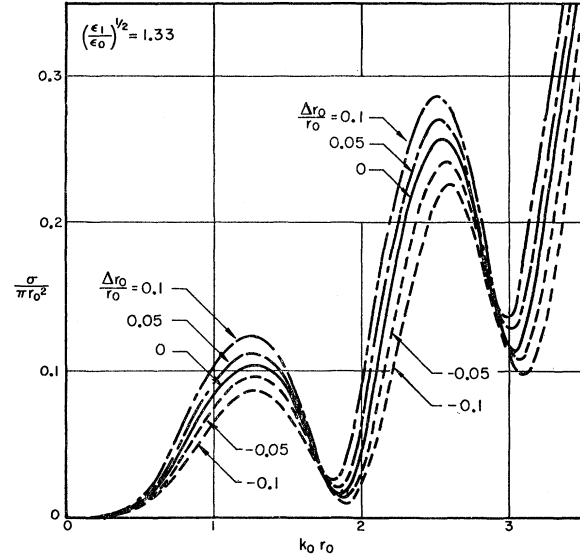

FIG. 3. The normalized backscattering cross sections for nose-on incidence.

are evaluated numerically by Simpson's rule. Five cases of the spheroidal shape are considered:

$$(r_0 + \Delta r_0)/r_0 = 0.9, 0.95, 1.0, 1.05, 1.1.$$

The normalized backscattering cross sections ($\sigma/\pi r_0^2$) as a function of $k_0 r_0$ for $0 \leq k_0 r_0 \leq 3.5$ for these five cases have been computed. Results are given in Fig. 3. Figure 4 shows the variation of the polarization of the scattered wave as a function of the polar angle θ with $k_0 r_0 = 2$ for various spheroidal shapes. The polarization is often defined as

$$P = (I_{||} - I_{\perp}) / (I_{||} + I_{\perp}).$$

For the present case under consideration, $I_{||} = I_\theta$ and $I_{\perp} = I_\phi$. It can be observed from these figures that, in general, polarization shows a greater sensitivity to the deformation of the spherical obstacle than does the normalized backscattering cross section.

It should be noted that although the numerical results given here are computed from the first-order solutions it is still expected that the results would be good approximation to the exact solutions for $|\Delta r_0/r_0| \leq 0.05$.

IV. CONCLUSIONS

The problem of the diffraction of electromagnetic waves by a dielectric body with perturbed boundary has been considered using the boundary perturbation technique. The solution is valid for the near zone (i.e., near the dielectric body) as well as for the far zone and is good for all frequencies. Since the perturbation solution satisfies Maxwell's equations, the boundary conditions, and the radiation condition for the scattered wave at infinity, hence it is unique. It should be noted that with slight modifications of Eqs. (20) through (23) the above derived results are also applicable for a

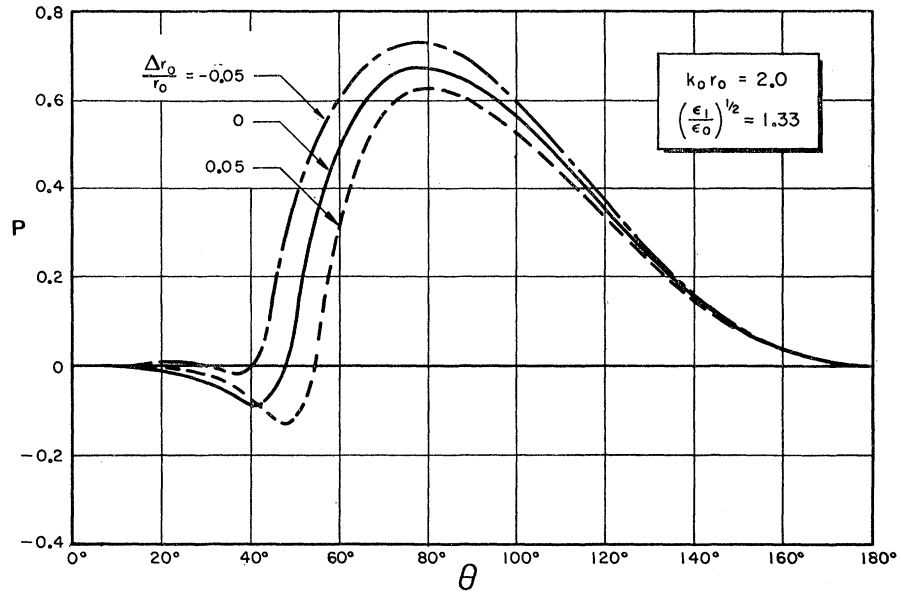

FIG. 4. The polarization of light scattered from dielectric spheroid for nose-on incidence.

radially inhomogeneous dielectric body with perturbed boundary.¹³

Further applications of this perturbation technique can be found in the scattering of electromagnetic or acoustic waves from hard or soft objects, in the scattering of x ray or of light by interstellar matter, and in elementary particle scattering theory.

ACKNOWLEDGMENTS

I wish to thank the reviewer for calling my attention to previous related work as represented by Ref. 10. I also would like to thank Mrs. G. Knudson of the Hughes Aircraft Company for providing the subroutines to compute Bessel functions. The use of the computing facilities at the Western Data Processing Center at UCLA is gratefully acknowledged.

¹³ C. Yeh, Phys. Rev. 131, 2350 (1963).

APPENDIX

The definite integrals J_{11n}^p , J_{21n}^p , J_{31n}^p , and J_{41n}^p are defined as follows:

$$J_{11n}^p = \int_0^\pi p(p+1) \frac{df_1}{d\theta} P_p^1 P_n^1 d\theta, \tag{A1}$$

$$J_{21n}^p = \int_0^\pi f_1 \left[\frac{dP_n^1}{d\theta} \frac{dP_p^1}{d\theta} + \frac{P_p^1 P_n^1}{\sin^2\theta} \right] \sin\theta d\theta, \tag{A2}$$

$$J_{31n}^p = \int_0^\pi f_1 \left[P_p^1 \frac{dP_n^1}{d\theta} + \frac{dP_p^1}{d\theta} P_n^1 \right] d\theta, \tag{A3}$$

$$J_{41n}^p = \int_0^\pi p(p+1) \frac{df_1}{d\theta} P_p^1 \frac{dP_n^1}{d\theta} \sin\theta d\theta, \tag{A4}$$

where $f_1 = \sin^2\theta$ and $df_1/d\theta = \sin 2\theta$.